Instruction Manual

Compact Size Gel Casting Kit
WSE-1091/WSE-1092

Multi Compact Gel Cast/Compact Gel Cast

1nd Edition
December 10th, 2024



Introduction

Thank you for purchasing ATTO Corporation's compact gel cast "WSE-1091/WSE-1092". This instruction manual is delivered to you together with the system so that you can make full use of it. Not only those of you using this product for the first time, but also those of you having used before should read this document carefully to understand contents. If you use this product for the first time, please read this document from beginning in serial order. In addition, this document contains information related to maintenance as well as how to use. Please keep it handy all the time to make its full use. If you have any questions on your purchased product or the instruction manual, please feel free to contact us. (Please refer to the back cover).

About this manual

Before using the product, please read this document carefully. After reading it, please be sure to keep it for your future reference. When you replace the system, be sure to attach this document to it. If there is any defect in this document such as misplaced or missing pages, or if this document is lost or stained, we will replace it with a new one. Please take a moment to contact the distributor you purchased the product from or our company (please refer to the back cover). At that time, please inform us of your product name and type. This document was created with our most careful attention; however, should you find any queries, errors or omissions, please inform our company (please refer to the back cover).

Safety precautions

To use this system safely, it must operate it properly. Do not use this product until you read this document carefully and understand the content sufficiently. Precautions on usage and safety described in this document are applied to the use of this product only for the specified purpose of use. Do not use this system for any purpose or by any method other than described here. If you use this system for any purpose or by any method other than described in this manual, you will be held responsible for any necessary safety measures as operator. If you operate the system for the first time, you need to be given instructions from an experienced operator with proper knowledge, and to understand its principle and method. Not only people operating this system for the first time but also people having ever used it after receiving professional education should keep this instruction manual handy to make its effective use. In order to prevent any damage to the system, please understand and follow the correct operation method shown in this manual. If you have questions or concerns related to the principle, maintenance or inspection, feel free to contact our company (please refer to the back cover).

Notices

Application	This system is physical and chemical equipment for research. It is not medical equipment. Therefore, it cannot be used for medical practices, such as care-related judgement or treatment effect checking.
Export	Export of certain services or cargos is controlled by the foreign exchange law and the government decree or ministerial ordinance of foreign trade control law of Japan. The product is subject to such regulations. Even if the product is not pertinent to the government decree, it is necessary to submit the document to the customs office to that effect. If the product is pertinent, it is necessary to obtain the export license from the Ministry of Economy, Trade and Industry, and submit the license to the customs office. When you export our company's product, please contact the distributor or our company's customer department in advance (please refer to the back cover).
Trademarks/ Copyright	Reprint or copy of a part or whole of the instruction manual would require the permission of the copyright. The specification of the product and the contents of the instruction manual may be changed without prior notice.

1 Overview

1.1 Purpose

WSE-1091/WSE-1092 is a gel cast for making polyacrylamide gel of compact size (60 x 60 x 0.75mm)

2 Inspection when unpacking

2.1 Inspection at unpacking

When you receive the product, check if the main unit and the accessories are properly packed and there is no damage. If you find any defect or damage, please contact the distributor you purchased the product from or our company immediately (please refer to the back cover). Carry out the inspection at the time of unpacking within one week after you receive the product. After one week elapses, damage or parts shortage may not be recovered.

2.2 Equipment configuration

The product consists of main unit and attachments.

Main unit

Product Name	Multi Compact Gel Cast	Compact Gel Cast
Model	WSE-1092	WSE-1091
Product No.	2393684	2393682
Main unit	Main unit of gel cast	Hold block
	Plate with packing	Packing block

Attachments

Model	WSE-1092	WSE-1091
Plate set (CAB-10, CB-00)	2	1
Smiling-less compact comb	2	1
Divider plate	6	
Dummy plate	1	
Silicon plate (22 x 71 mm)	2	
Silicon plate (22 x 80 mm)	1	
Instruction manual		1

Materials

WSE-1092	WSE-1091
Main unit : Acrylic, Stainless steel	Hold block : Acrylic, Stainless steel
Plate with packing : Acrylic, stainless steel, Silicon sponge	Packing block : Acrylic, Stainless-steel, Silicon packing
Silicon plate : Silicon	
Divider plate : Polycarbonate	
Dummy plate : Acrylic	
Smiling-less compact comb : Polypropylene	

3 Name and function of each parts

① Main unit of Compact Gel Cast

This is for making compact size gel. With standard attachment, WSE-1091 is intended to make 1 gel, on the other hand WSE-1092 is intended to make 2 gels. It is available for making max. 4 gels with additional 2 pairs of glass plates by WSE-1092. With optional 2D comb, it is possible to make a 2D gel for agarose 2D electrophoresis.

WSE-1091

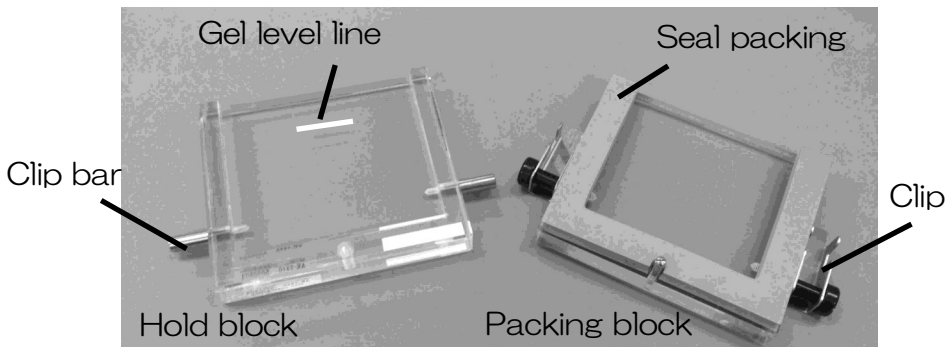

WSE-1092

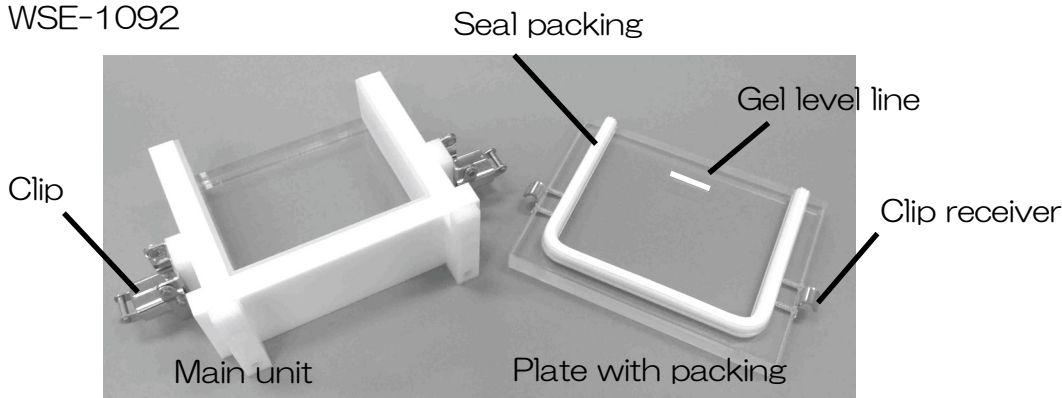

② Notched plate (WSE-1092: 2 plates, WSE-1091: 1 plate)

Place the spacer side up and put plain plate on it. Gel is made in the space between 2 plates.

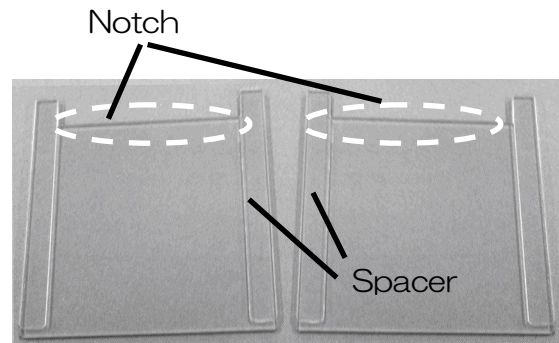

③ Plain plate

(WSE-1092: 2 plates, WSE-1091 : 1 plate)

Place the spacer side of notched plate up and put plain plate on it. Gel is made in the space between 2 plates.

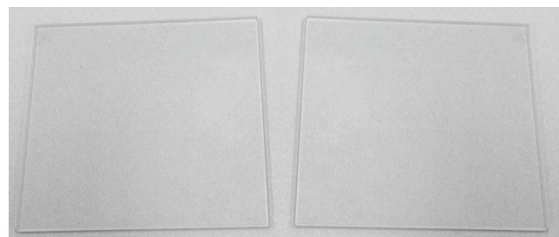

④ Divider plate (WSE-1092 only: 6 plates)

This plate is inserted between pair of glass plates and another pair for preventing from making surplus gel and for removing gel from plates easily.

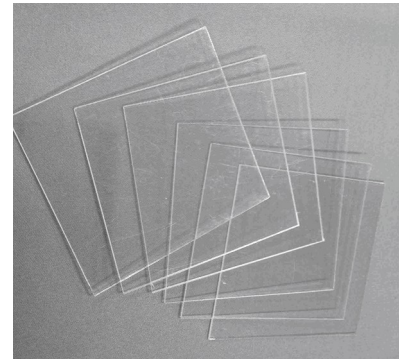

⑤ Dummy plate (WSE-1092 only)

When 2 gels are made, this plate is inserted to the space of main unit. In the case of making 4 gels, this plate is not used.

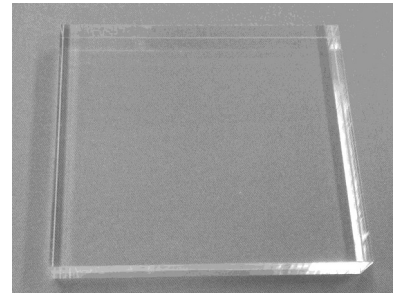

⑥ Smiling-less compact comb (WSE-1092 : 2 combs, WSE-1091: 1 comb)

This is 12-well comb for making wells on gel.

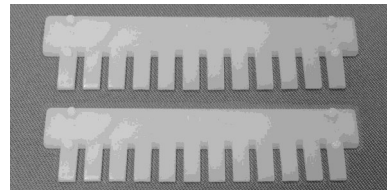

⑦ Silicon plate (WSE-1092 only)

This silicon plate is set on the bottom and side of main unit. The length of silicon plate (a) is different from that of (b) even though the width is the same. This product includes a 22x80mm plate (a) and two 22x71mm plates (b). Plate (a) is set on the bottom of the system and then plate (b) is set on the each side of it.

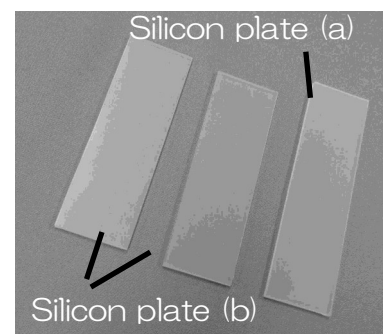

4 Gel preparation

Assemble gel casting system and prepare gel solution for making gel.

It needs about 20mL separation gel solution and 10mL stacking gel solution for making 4 sheets of gel.

4.1 Assembling a gel cast

It explains how to assemble WSE-1091 and WSE-1092 system in the below. Please put clean gloves on for experiment when you operate.



Warning

Monomer of acrylamide has neurotoxicity.
Protect your body with gloves etc.



If you operate with bare hands, experimental tools, solution and anything related to the operation may be contaminated, and it is difficult to get the best experimental result.

Also, if the plates are contaminated, air bubbles may occur easily when gel solution is being put into the system. Be sure to clean it sufficiently.

Do not fix the system by clips except when making gels. If you do, elasticity of seal packing is lost and it may cause liquid spill when making gels.

WSE-1092 Multi Compact Gel Cast

Separate main unit from plate with packing. Set a 22x80mm silicon plate on the bottom and two 22x71mm silicon plates on the each side of main unit.

Separate main unit from plate with packing.

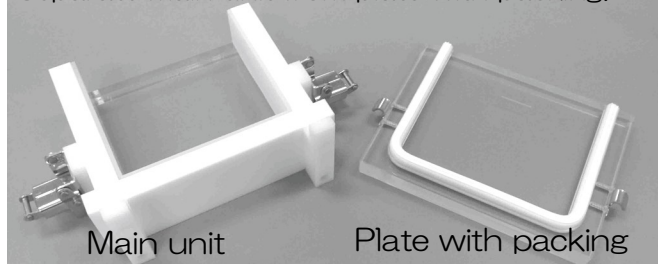

Set 1 divider plate to main unit.

Set 1 divider plate.

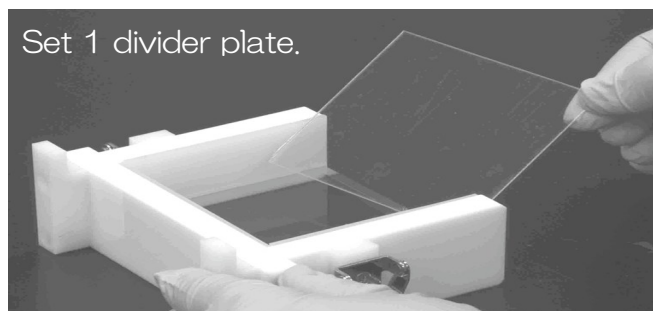

Set 1 notched plate to main unit so that spacer faces to upward and notch on the right side like the image.

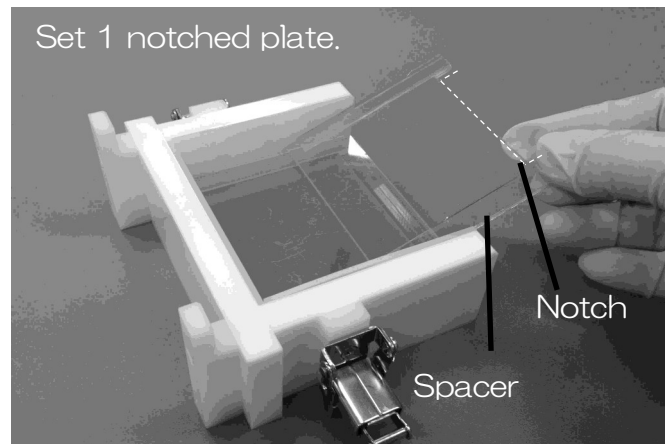

Set 1 plain plate on the notched plate.

The set of notch and plain plate is called "plate set".

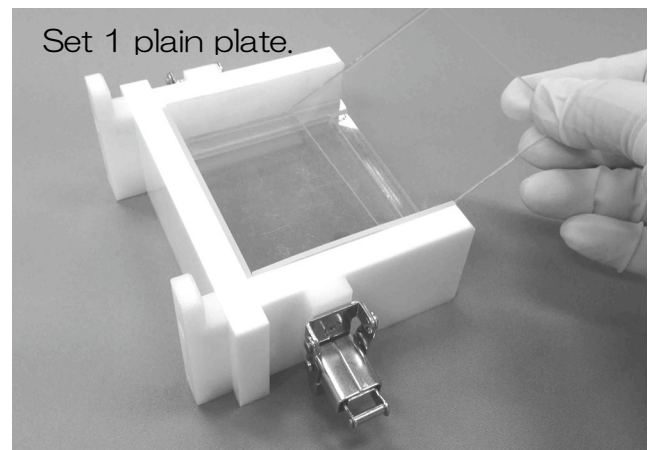

Set 2nd divider plate on the plain plate.

Set 2nd plate set as same as 1st time.

And then, set 3rd divider plate.

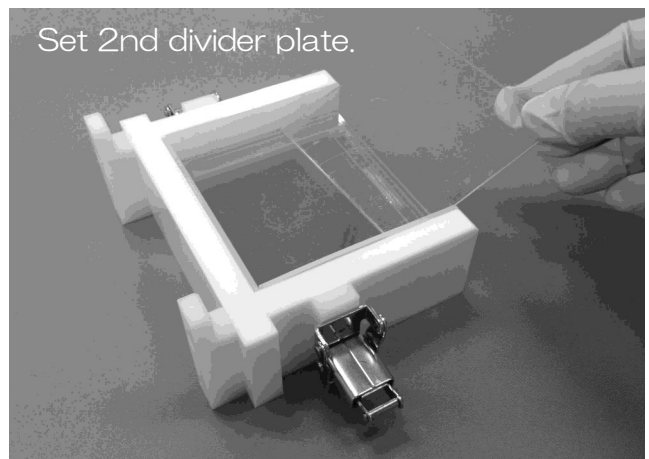

Set a dummy plate.

At this time, confirm all plates (notch x2, plain x2, divider x3 and dummy x1) touch to the bottom of main unit.

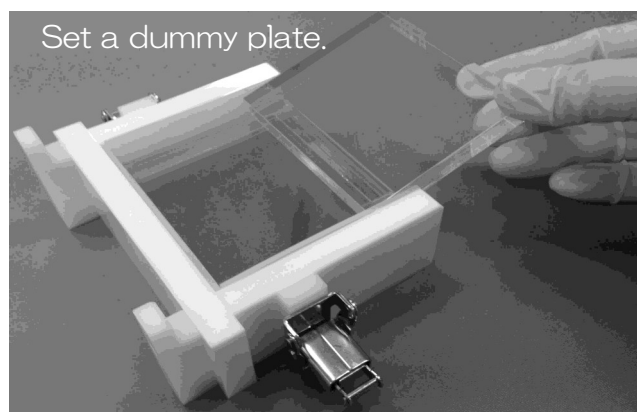

Confirm all plates are set properly; right and left side of plate don't get out of position. If it gets out of position, reset plates or use a tool whose tip is flat like spatula for setting.

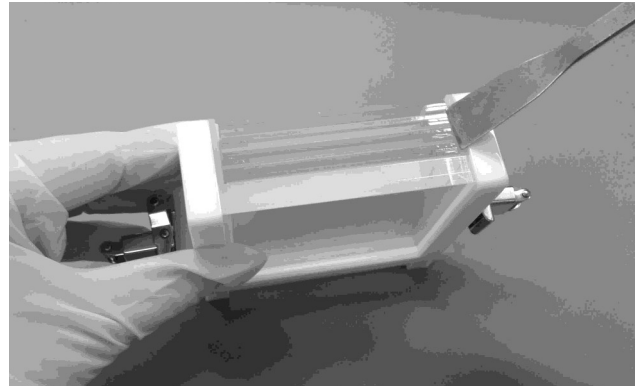

Finally, set 1 divider plate and then plate with packing.

Fix plates by right and left clips uniformly.

When you make 4 sheets of gel, set 3rd plate set instead of dummy plate on the 3rd divider plate, and then put in order of 4th divider plate and 4th plate set.

Fix plates by clips.

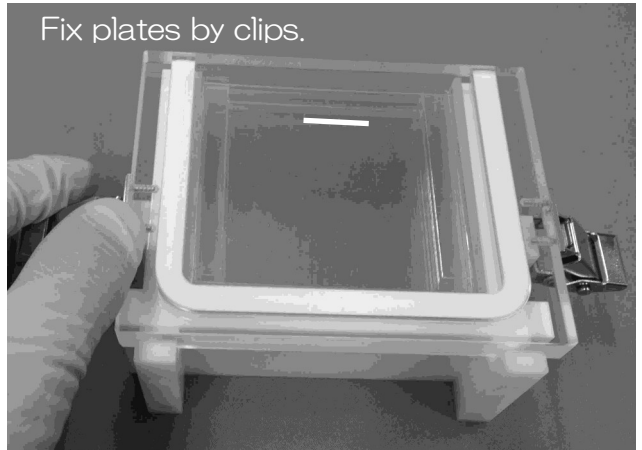

Stand the system upright and confirm notch and plain plate cohere well.

If there is a gap, confirm all plates are set correctly.

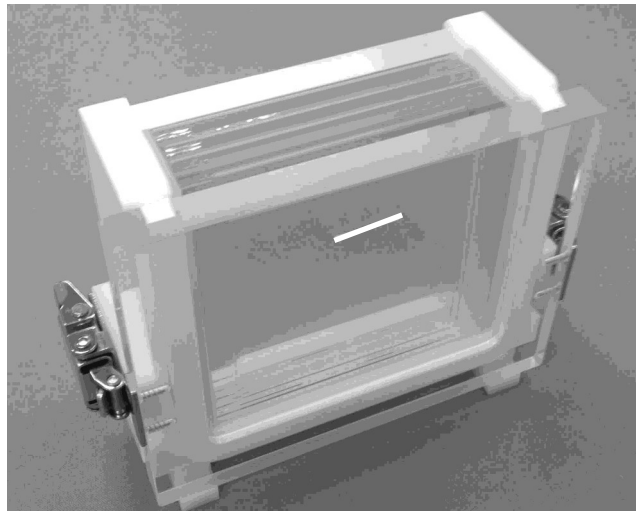

Gel may be made between spacer of notched plate and plain plate and it may affect migration.

If there is a gap between plates set correctly, add one more divider plate for attaching spacer to plain plate.

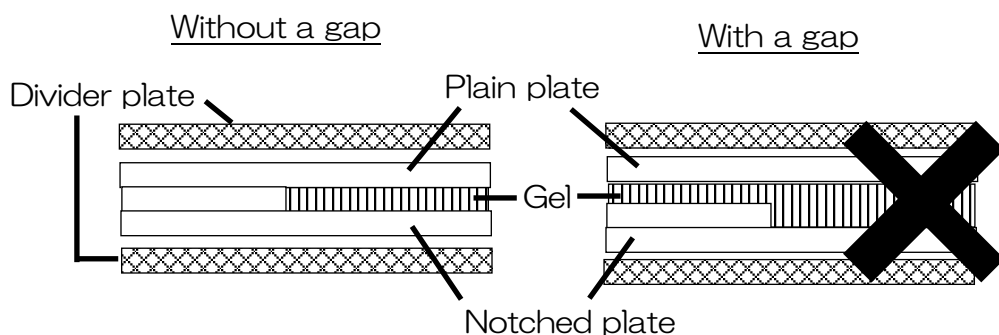

WSE-1091 Compact Gel Cast

Separate hold block from packing block.

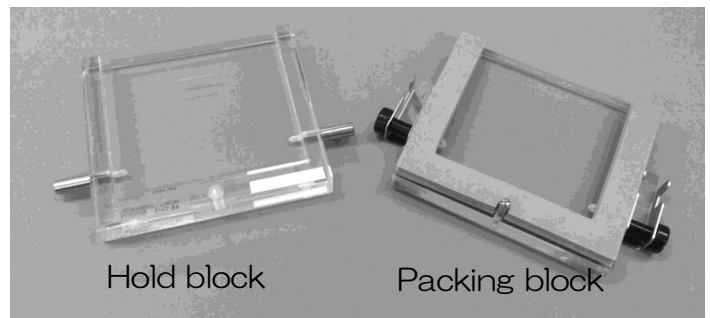

Set 1 notched plate to hold block so that spacer faces to upward and notch on the right side like the image.

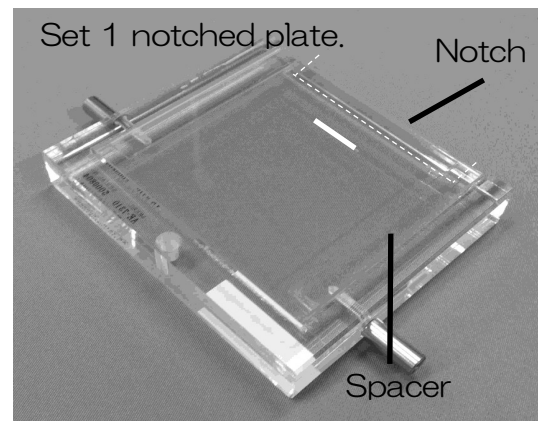

Set 1 plain plate on the notched plate.

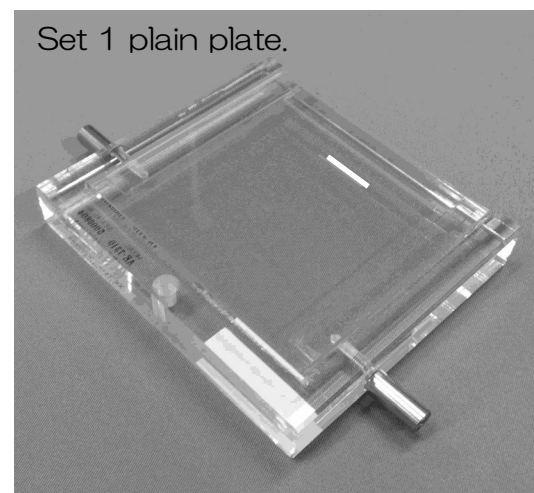

Confirm plates are not deviated to right or left side. If plates are not set correctly, reset them.

Set packing block on the hold block and fix plates by clips and clip bars.

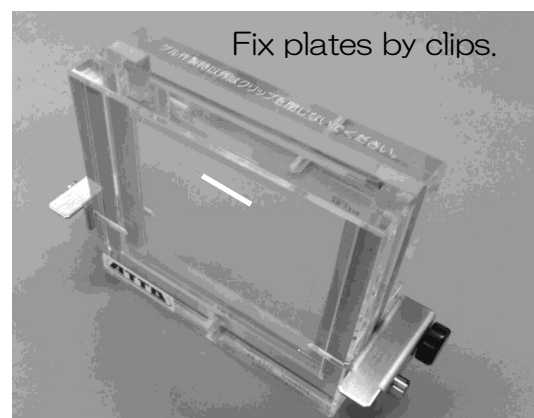

4.2 Gel casting

This chapter explains with WSE-1092. In the case of using WSE-1091, the same operation for gel casting is performed.

Please select concentration depending on molecular weight of sample. In the case of native PAGE, charge state of sample affects mobility greatly. So, concentration cannot be selected on the basis of only molecular weight of sample. It needs preliminary experiment for selecting.

Pour separating gel solution gently into the assembled system from notch part. If the solution is poured vigorously, uneven polymerization may occur.

Do not put air bubbles in.

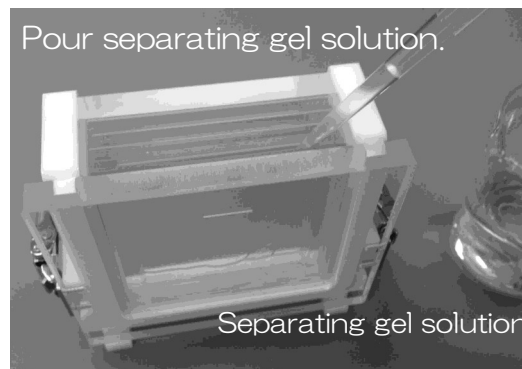

When about 1/3 of separating gel solution is poured, tilt the system to back and forth or right and left for spreading it on the whole.

If there are air bubbles between plates, tilt main unit and so on to remove them.



Pour separating gel solution up to separating gel level line marked on plate with packing. Tilt main unit and so on for adjusting each height of solution between plates to be same level.

In the case of making gel for DNA, pour the solution up to the upper end of glass plate.

*In the case of making gel for DNA with WSE-1091, pour gel solution up to notch of glass plate.

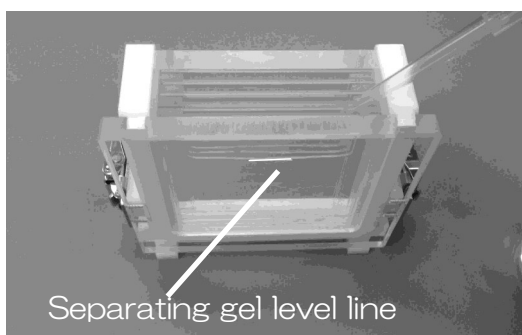

Slowly put distilled water on the each separating gel solution until the height which is 2-3mm higher than the surface of gel solution and keep it still for more than 30min to let polymerization happen.



Put distilled water on separating gel solution equally. If the amount is different from each, distance of separating gel is not uniform.



At low temperature (less than 20°C), polymerization is difficult to occur. The polymerization speed is varied by temperature. Let polymerization occur always at a constant temperature so as to maintain reproducibility of the electrophoretic pattern.

In the case of making gel for DNA, insert sample comb until the stopper touches the notch of plate.

In the case of making gel for 2D electrophoresis, put separating gel solution in up to the height which is 3mm lower than notch of plate.



Stopper

2D compact flat comb



There is a cut on upper end of the comb.

After polymerization is completed, discard the distilled water. At this time, hold main unit gently for preventing plates from slipping out and tilt it to discard distilled water. In the case of making gel for DNA, this process is not necessary.

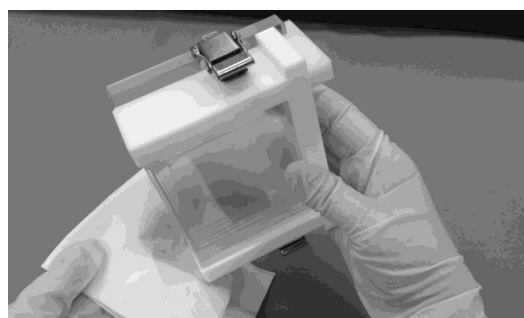

Pour stacking gel solution up to the upper end of plate.

*In the case of making gel with WSE-1091, pour gel solution up to notch of



Pour stacking gel solution.

Insert sample comb until the stopper touches the notch of plate.

Polymerization will be completed in about 30min. As for 2D flat comb, put the comb on the notch part of glass plate.



Insert comb.



Be careful not to attach air bubbles to the teeth of comb. If you do, the well will not be formed properly.

Take gels out from the main unit after confirming gelation is completed. Place main unit down and unlock the right and left clip.

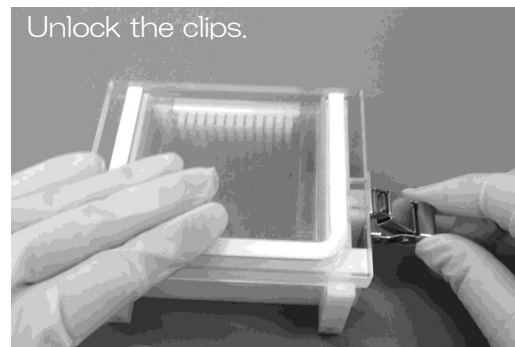

Remove plate with packing.

Remove plate sets and divider plates, and take gels out from main unit one by one.

Wash away gel solution attached to plates with distilled water soon. Remove unnecessary gel attached to comb by a tool like spatula.

If the gel is not used for electrophoresis soon, wrap in a shroud for preventing it from drying.

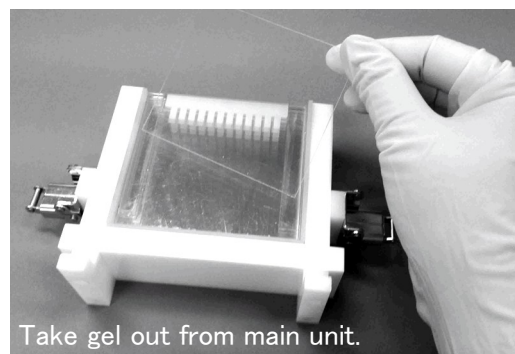

5 How to Clean and store the system

5.1.Cleaning

Clean glass plates & combs by soft sponge with neutral detergent so as not to leave bits of gel before drying. Then, dry them naturally. If they touch organic solvent such as acetone, alcohol and so on or are dried at high temperature, it may cause crack, deformation and discoloration.

Clean and dry naturally gel cast, divider and dummy plates as well as glass plates. Prevent from using a sponge made of metal for cleaning them. If you do, they are damaged so visibility at the time of making gels is reduced.

5.2.Storing the system

Store the system in an area out of direct sunlight, high temperature, or corrosive gas. Do not fix gel cast by clips except when you make gels. The elasticity of seal packing is reduced and it may cause leak when to make gels.

6 Trouble shooting

Symptoms	Cause	Solution
Gel solution leaks.	The system is not assembled correctly.	Confirm glass plates etc. are set in the system and fix them by clips correctly. If glass plates etc. are out of position, refer to “4.1 Assembling a gel cast” and assemble it again. If the lock is incomplete, fix the system by clips again.
	Seal packing is twisted or wrinkled.	Confirm seal packing has no twist and wrinkle. If that of WSE-1092 has, remove seal packing from the system and reset it without twist and wrinkle. In the case of WSE-1091, please contact our company.
	Seal packing deteriorates.	Refer to “7.2 Inspection” and check water leakage. If there is leakage, please contact our company.
Well is shallow.	stacking gel solution is not enough.	In the case of WSE-1092, after inserting comb, solution may flow out to the gap between glass plate and cast, and surface of liquid lowers. Fill gel solution up to the upper end of glass plates.
Unnecessary surplus gel is made at the right and left hand of glass plates, or on the bottom.	Silicon plate is not set in main unit of WSE-1092.	Set silicon plate (a) on the bottom and silicon plate (b) in the right and left hand of main unit.
2 pairs of glass plates cannot be separated.	Divider plate is not set.	Set a divider plate between a pair of plates and another pair.
Gel is made at the spacer.	Plain and notched plate don't cohere enough.	Refer to “4.1 Assembling a gel cast” and assemble it. If plates don't cohere each other in WSE-1092 system, add one more divider plate.

7 Maintenance

7.1 Cleaning

Before drying, remove clean gel cast, divider plates and dummy plates so as not to leave bits of gel by soft sponge with neutral detergent, then dry them naturally. If they touch organic solvent such as acetone, alcohol and so on or dried at high temperature, it may cause crack, deformation and discoloration. Prevent from using a sponge made of metal for cleaning them. If you do, they are damaged so visibility at the time of making gels is reduced.

7.2 Inspection

When the system is used after storing, read this manual at the same time to inspect it. If there is an abnormality, do not use it and contact our company.

If the seal packing of WSE-1092 Multi Compact Gel Cast is out of position or twisted, reset it correctly. Also if there is a lateral wrinkle at the curve of the bottom, reset it, too.

In the case of WSE-1091, confirm seal packing is not peeled off and there is no wrinkle or dent.

Refer to “4.1 Assembling a gel cast” and assemble the system. Pour pure water in up to 0.5-1cm from the upper side and keep it quietly for 1 hour. Check there is no leakage.

7.3 Consumables

The following goods are consumables for WSE-1091/WSE-1092. Please replace with new one depending on the condition. For the goods not described in the below, contact your distributor or our company.

Product name	Code No.
Notch Glass plates 2/pk, CP	2393691
Plain Glass Plates 2/pk, CP	2393637
Dummy Plate, CP	2394060
Divider Plate 3/pk, CP	2394062
Silicon plates for WSE-1090/1092 3/pk	2393628
1.0mm 12-well Combs 2/pk, CP	2393695
2D Comb 2/pk, CP	2394065

7.4 Warranty

Atto Corporation warrants all its products subject to the terms and conditions set forth below.

1. This warranty covers all new products that are sold by Atto Corporation (hereinafter called Atto).
 2. Expendable items are not covered by this agreement.
 3. Claims under this warranty are limited to defects in material and workmanship of the products.
 4. Malfunction and/or damage due to neglect, abuse, operation or repair contrary to specifications and/or instructions presented by Atto are not warranted.
 5. Atto shall not be liable to consequential damage, labor, loss or expense directly or indirectly arising from us of the products.
 6. Damage due to transit is not covered by this warranty.
 7. The warranty period is one (1) calendar year from a date when the products are shipped from Atto to an original purchaser.
 8. This warranty is not applied to any defect that is reported to Atto later than one (1) calendar month from a date of warranty termination.
-
-

9. Atto Shall supply parts to replace faulty parts of defective products under this warranty, free of charge.
10. Atto shall repair defective products under this warranty which cannot be repaired at field, free of charge.
11. Atto shall replace defective products under this warranty which cannot be repaired, free of charge.
12. Freight charges for return and replacement shipments under this warranty are shared by Atto and a purchaser, that is one way by either party and another way by another party.
13. Warranty period of repaired products and replacement products or parts is three (3) calendar months from a date when the said products or parts are shipped from Atto, or a remaining term of an original warranty period of the defective products, whichever lasts longer.
14. Return of the products for credit or refund is not accepted unless otherwise agreed in writing by Atto.

8 Specification

Product name	Compact Gel Cast
Model	WSE-1091
Plate size (W x H x D , mm)	76 x 70 x 5
Gel size (W x H x D , mm)	60 x 60 x 0.75
Number of gel	1 sheet
Location of use	Only use in a room. No dew condensation. Operation ambient temperature: 5~40°C Operation ambient humidity: 5~70%RH
Dimension/Weight	45mm(D) × 93mm(W) × 75mm(H) (Without clip part) 0.2Kg
Standard components	Main unit 1 set Glass plates 1 pair (CAB-10 Notch, CB-00 Plain) Smiling-less compact comb 1 comb Instructional manual

Product name	Multi Compact Gel Cast
Model	WSE-1092
Plate size (W x H x D , mm)	76 x 70 x 5
Gel size (W x H x D , mm)	60 x 60 x 0.75
Number of gel	Max. 4 sheets (Standard: 2 sheets)
Location of use	Only use in a room. No dew condensation. Operation ambient temperature: 5~40°C Operation ambient humidity: 5~70%RH
Dimension/Weight	45mm(D) × 113mm(W) × 97mm(H) (Without clips) 0.3Kg
Standard components	Main unit 1 set Glass plates 2 pairs (CAB-10 Notch, CB-00 Plain) Smiling-less compact comb 2 combs Divider plate 6 plates Dummy plate 1 plate Instruction manual



ATTO Corporation

Head Office: 3-2-2 Motoasakusa,
Taito-ku, Tokyo 111-0041, JAPAN

Website: <https://www.attoeng.com/>